

S-C CLASS

SOFT SEATED BALL VALVES

MAINTENANCE MANUAL



S-CLASS CUTAWAY

- 1 Clearview Mounting Pad
- 2 Jam Nut
- 3 Tab Washer
- 4 Packing Belleville Washer
- 5 Wear Washer
- 6 Extended Bonnet
- 7 Upper Stem Guide
- 8 Packing Belleville Washer
- 9 Packing Follower
- 10 Stem
- 11 Gland Packing
- 12 Bonnet Studs
- 13 Bonnet Belleville Washer
- 14 Bonnet Gasket
- 15 Lower Stem Guide
- 16 Sealmaster
- 17 End Cap Seal
- 18 Downstream Seat
- 19 Ball
- 20 End Cap - Downstream
- 21 End Cap - Upstream
- 22 Upstream Seat
- 23 Body
- 24 End Cap Studs
- 25 End Cap Belleville Washer

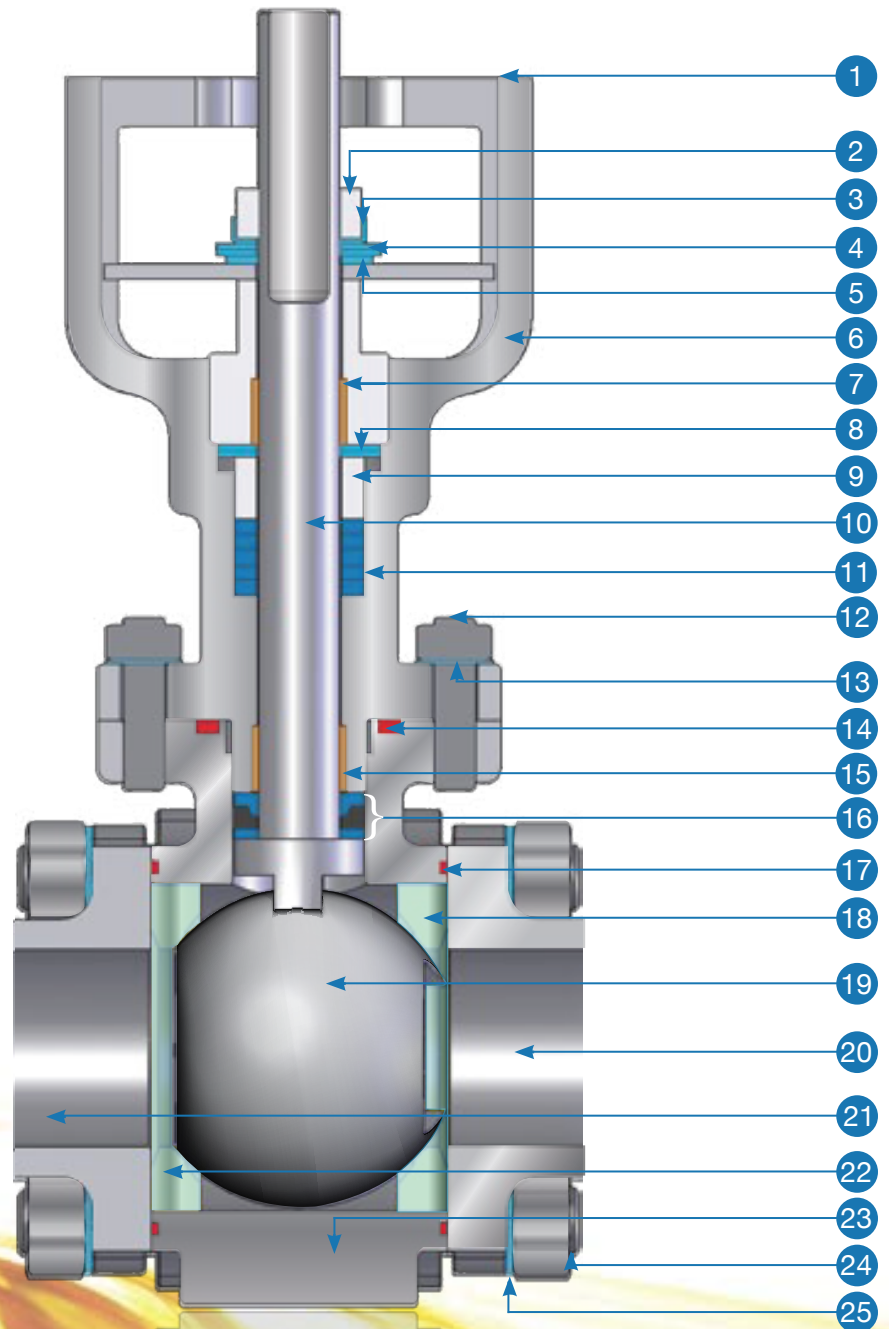

S-CLASS MAINTENANCE

Rebuild Procedure

A full rebuild is necessary when valve leakage is detected or stem packing adjustments do not prevent stem leakage. It is recommended that the valve be removed from the pipeline before disassembly.

Note: Ball valves can hold pressure for extended periods when in the closed position. It is recommended that the valve be cycled, relieving any residual pressure before removing from the pipeline. Extra attention and precautions must be taken when removing the valve from a process line, as media may be trapped within the body cavity or process piping.

1) Body and Seat

1. Ensure valve is in the open position so that ball will not fall out. Remove flanges from body.
2. Replace seals as indicated in replacement parts table.
3. Reassemble flanges with Belleville washers and torque nuts as specified in "Fastener Nut Torques" (table 4).

2) Bonnet

1. Remove bonnet by unscrewing the nuts from studs at base of bonnet.
2. Lift bonnet straight out of body.
3. Replace bonnet gasket with replacement indicated in the replacement parts table.
4. Reassemble flanges with Belleville washers and torque nuts as specified in "Fastener Nut Torques" (table 4).

3) Replace Stem Packing

1. Remove the following items in the specified order, first to last: tab washer, jam nut, wear washer, gland Bellevilles, flat washer, gland nut, gland Bellevilles, packing follower, gland packing.
2. Replace gland packing, then reassemble the above items in reverse order.
3. Tighten jam nut until gland Belleville washers flat, then fold up tabs on tab washer.

4) Adjusting Stem Packing

1. Tighten gland nut to torque indicated in table 5. Tighten jam nut, until gland Bellevilles are flat.

3 Piece Dual Pak Valve Replacement Part Numbers (table 1)

Valve Size (FP)	Gland Packing		Tab Washer	Sealmaster		Bottom Plug Seal		Bonnet Seal		Body Seal		Seat	
	Chevron	Graphoil		TFE	TCF	PTFE	Graphoil	TFE	TCF	TFE	TCF	TFE	TCF
1/2	DPV10102	DPV10676	DPV10333	DPV10447	DPV10060	DPV11223	DPV11218	DPV20838	DPV20948	DPV10409	DPV10519	DPV10345	DPV10080
3/4	DPV10102	DPV10676	DPV10333	DPV10447	DPV10060	DPV11223	DPV11218	DPV20838	DPV20948	DPV10410	DPV10520	DPV10346	DPV10081
1	DPV10103	DPV10677	DPV10334	DPV10448	DPV10061	DPV11224	DPV11219	DPV20838	DPV20948	DPV10411	DPV10521	DPV10347	DPV10082
1-1/4	DPV10103	DPV10677	DPV10334	DPV10448	DPV10061	DPV11224	DPV11219	DPV20838	DPV20948	DPV10412	DPV10522	DPV10348	DPV10083
1-1/2	DPV10104	DPV10678	DPV10335	DPV10449	DPV10062	DPV11225	DPV11220	DPV20839	DPV20949	DPV10413	DPV10523	DPV10349	DPV10084
2	DPV10104	DPV10678	DPV10335	DPV10449	DPV10062	DPV11225	DPV11220	DPV20839	DPV20949	DPV10414	DPV10524	DPV10350	DPV10085
2-1/2	DPV10105	DPV10679	DPV10336	DPV10450	DPV10063	DPV11226	DPV11221	DPV20950	DPV20950	DPV10415	DPV10525	DPV10351	DPV10086
3	DPV10105	DPV10679	DPV10336	DPV10450	DPV10063	DPV11226	DPV11221	DPV20950	DPV20950	DPV10416	DPV10526	DPV10352	DPV10087
4	DPV10106	DPV10680	DPV10337	DPV10451	DPV10064	DPV11226	DPV11221	DPV20950	DPV20950	DPV10417	DPV10527	DPV10353	DPV10088

2 Piece Dual Pak Valve Replacement Part Numbers (table 2)

Valve Size (FP)	Gland Packing		Tab Washer	Sealmaster		Bottom Plug Seal		Bonnet Seal		Body Seal		Seat	
	Chevron	Graphoil		TFE	TCF	PTFE	Graphoil	TFE	TCF	TFE	TCF	TFE	TCF
1/2	DPV10102	DPV10676	DPV10333	DPV10447	DPV10060	DPV11223	DPV11218	DPV20838	DPV20948	DPV11449	DPV11442	DPV11469	DPV11462
3/4	DPV10102	DPV10676	DPV10333	DPV10447	DPV10060	DPV11223	DPV11218	DPV20838	DPV20948	DPV11449	DPV11442	DPV11470	DPV11463
1	DPV10103	DPV10677	DPV10334	DPV10448	DPV10061	DPV11224	DPV11219	DPV20838	DPV20948	DPV11450	DPV11443	DPV11471	DPV11464
1-1/2	DPV10104	DPV10678	DPV10335	DPV10449	DPV10062	DPV11225	DPV11220	DPV20839	DPV20949	DPV11451	DPV11444	DPV11472	DPV11465
2	DPV10104	DPV10678	DPV10335	DPV10449	DPV10062	DPV11225	DPV11220	DPV20839	DPV20949	DPV11452	DPV11445	DPV11473	DPV11466
3	DPV10105	DPV10679	DPV10336	DPV10450	DPV10063	DPV11226	DPV11221	DPV20950	DPV20950	DPV11453	DPV11446	DPV11474	DPV11467
4	DPV10106	DPV10680	DPV10337	DPV10451	DPV10064	DPV11226	DPV11221	DPV20950	DPV20950	DPV11454	DPV11447	DPV11475	DPV11468

Repair Kit* (table 3)

Valve Size	Kit Part Number
1/2	RPK-01TFECHV
3/4	RPK-02TFECHV
1	RPK-03TFECHV
1-1/4	RPK-04TFECHV
1-1/2	RPK-05TFECHV
2	RPK-06TFECHV
2-1/2	RPK-07TFECHV
3	RPK-08TFECHV
4	RPK-09TFECHV

*Kit includes: Chevron gland packing, tab washer, TFM1600 Sealmaster, bonnet & body seal, TFM1600 seats

Fastener Nut Torques (table 4)

Fastener	Torque (in.lbs)
5/16"-18	145
3/8"-16	259
7/16"-14	416
1/2"-13	639
9/16"-12	925
5/8"-11	1279
3/4"-10	2288
7/8"-9	3709
1"-8	5568

Gland Nut Torques (table 5)

Valve Size	Torque (in.lbs)
1/2	137.5
3/4	137.5
1	233
1-1/4	233
1-1/2	361
2	361
2-1/2	740
3	740
4	955